

## Features Independent Inspection Table Independent From Bench

### General Information

A Horizontal Flow Clean Bench, as pictured, provides Class 100 HEPA filtered air in a horizontal laminar flow pattern across an isolated inspection table. The Inspection Table is independent from the Clean Bench for vibration-free applications.

### Inspection Table

Isolation Inspection Table (as shown) utilizes a backlit translucent acrylic work surface on a powdercoated frame.

### Air Flow and Filtration

Air is taken into the unit through a pleated type, disposable prefilter rated at 30% ASHRAE efficiency, then passes through the final HEPA or ULPA filter. The standard HEPA filter is 99.99% efficient @ 0.3 micron or larger. The ULPA grade filter is 99.9995% efficient @ 0.12 micron and is available as an option. Final filters are easy to replace from the front of the unit.

### Magnehelic Gage

A panel mounted Magnehelic Gage monitors HEPA filter static pressure. Pressure increases in correlation with a dirty filter indicate that a new HEPA filter is required. Filter life is dependent on frequency and type of use of the clean bench.

### Clean Bench Lighting

All models are equipped with a 4-lamp light fixture, 120 volt, 60 hz with a T8 electronic ballast. Fluorescent light tubes are not furnished with the units because of potential breakage during shipment.

Horizontal Flow Clean Bench  
w/Isolated Inspection Table



## Horizontal Flow Clean Bench With Isolated Inspection Table

### Filtered Air

Incoming Air passes into two (2) prefilters and is filtered through a HEPA final filter.

### Construction

Clean Bench frames are white painted steel tubing with adjustable leg levelers and clear acrylic side panels. Side panels slide out for easy cleaning.

### Electrical

Standard voltage is 115 volts with 208-230 (50/60 hz) and 277 (60 hz) volts available as options. An On/Off switch and Variable Speed Control are located within easy reach of the operator.

All 115 volt models are equipped with a 8 foot power cord and 3 - prong plug. Other voltages require electrical connection to the power source by a qualified electrician.

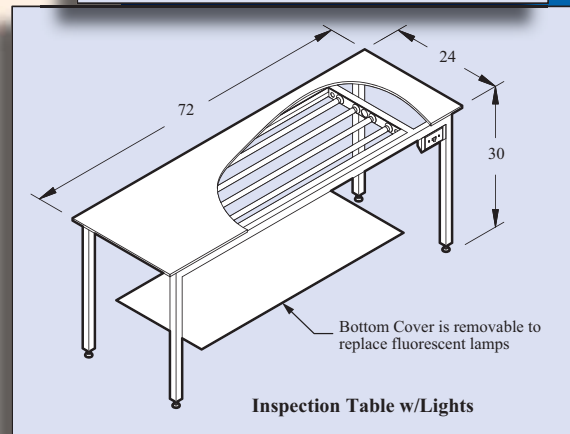
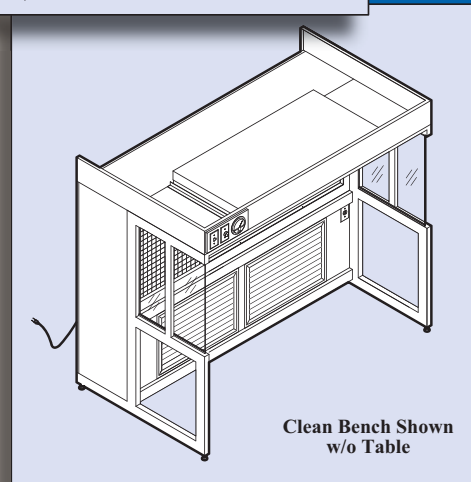
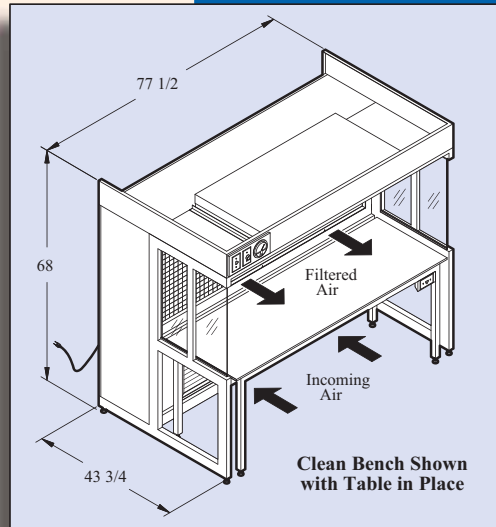

### Ordering Information

Mfg. Code	Description
13014	Horizontal Flow Bench, 115V
13015	Inspection Table w/Lights

### Replacement Filters

Mfg. Code	Description
302130	HEPA CRF Filter, 99.99% eff. @ 0.3 micron (Standard)
302131	ULPA CRF Filter, 99.9995% eff. @ 0.12 micron (Optional)
309803	Prefilter 16" x 25" x 1" (2 req'd.)